

CAD FILE :

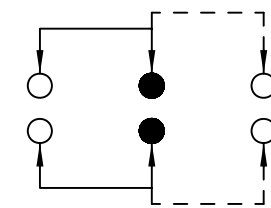

SCHMATIC (NON-SHORTING)

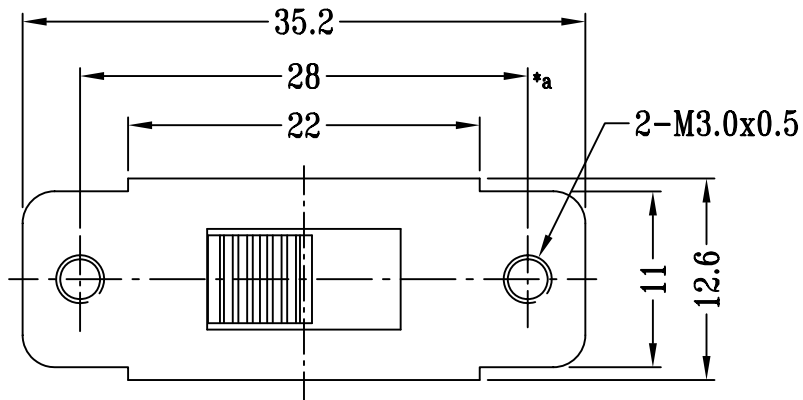
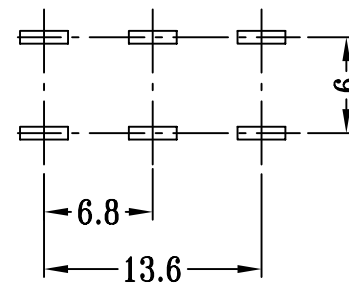
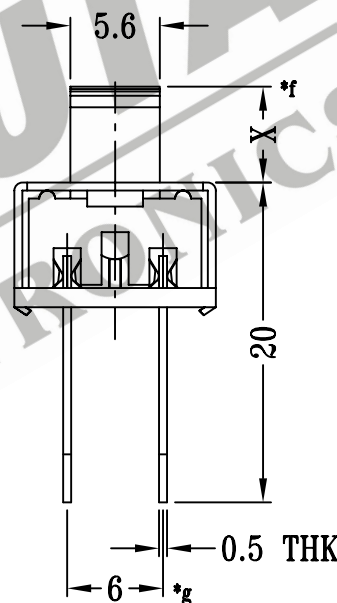
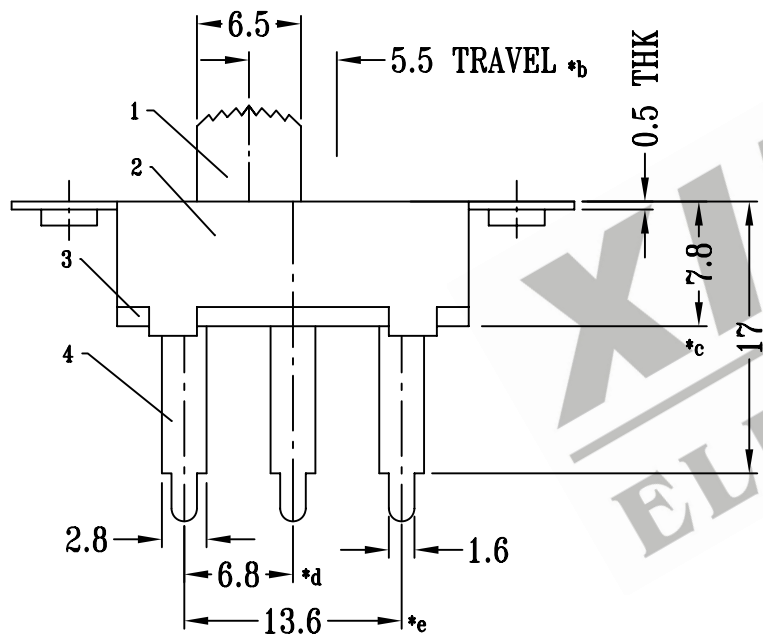

P.C.B LAYOUT

注:带*表示关键尺寸(7个)

8	CONTACT CLIP	PBS STRIP	2	Ag PLATED
7	POSITION PLATE	STEEL STRIP	1	Ni PLATED
6	STEEL BALL	STEEL	1	NATURAL
5	SPRING	STEEL WIRE	1	TEMPER
4	TERMINAL	BRASS STRIP	6	Ag PLATED OVER Ni PLATED
3	TERMINAL BASE	PHENOLIC RESIN	1	BLACK
2	FRAME	STEEL STRIP	1	Zn PLATED
1	KNOB	PC	1	BLACK
NO.	PART NAME	MATERIAL	QTY.	FINISHING

TOLERANCE UNLESS SPECIFIED		SHENZHEN XIEJIA ELECTRONICS CO.,LTD.		
WITHIN: 1.5±0.1mm OVER : 1.5±0.2mm		ISSUE	DATE	DESCRIPTIONS
TITLE: VERTICAL SLIDE SWITCH		UNIT : M M	DRWG NO : XJ-DR-SS22K34-00	
MODEL: SS-22K34		SCALE : 2:1	DWN.	ZHOUYU
ALL MATERIALS MUST BE COMPLIANT TO ROHS		APPD.	KANGXINAN	2005-4-17